

**Interconnection Standards for  
Installation and Parallel Operation of  
Customer-Owned Renewable Electric  
Generation Facilities 25 kW<sub>AC</sub> or Less**



**HamiltonUtilities**  
powered by you

**City of Hamilton, Ohio  
Electric Department**

---

**Adopted July 23, 2018**

# Contents

PART 1. OVERVIEW .....	4
1. PURPOSE: .....	4
2. DEFINITIONS: .....	4
3. ELIGIBILITY:.....	6
4. INTERCONNECTION REQUEST: .....	7
5. ELECTRIC DISTRIBUTION SYSTEM IMPACT ANALYSIS: .....	7
6. SYSTEM UPGRADES: .....	9
7. INTERCONNECTION AGREEMENT:.....	10
8. CODES AND PERMITS: .....	10
9. CERTIFICATE OF COMPLETION:.....	10
10. NORMAL OPERATION:.....	10
PART 2. TECHNICAL REQUIREMENTS.....	11
1. CHARACTER OF SERVICE: .....	11
2. CODE REQUIREMENTS: .....	11
3. GENERATION FACILITY CONTROL: .....	11
4. LIMITS SPECIFIC TO SINGLE-PHASE GENERATING FACILITIES:.....	11
4.1 LIMITS SPECIFIC TO THREE-PHASE GENERATING FACILITIES:.....	12
5. SYSTEM PROTECTION: .....	12
6. FAULT CURRENT DISCONNECTION: .....	12
7. RECLOSING COORDINATION: .....	13
8. EXTERIOR GENERATION FACILITY AC DISCONNECT SWITCH: .....	13
9. STANDARDS FOR INTERCONNECTION, SAFETY AND OPERATING RELIABILITY: .....	13
10. ACCESS AND INSPECTION BY UTILITY:.....	14
11. GENERATION FACILITY OPERATION:.....	14
12. RIGHT TO DISCONNECT GENERATION FACILITY: .....	15
13. RATES AND OTHER CHARGES:.....	16

14.	INSURANCE: .....	16
15.	LIMITATION OF LIABILITY AND INDEMNIFICATION: .....	17
16.	EFFECTIVE TERM AND TERMINATION RIGHTS: .....	18
17.	TERMINATION OF ANY APPLICABLE PRIOR AGREEMENT: .....	19
18.	FORCE MAJEURE: .....	19
PART 3.	INTERCONNECTION APPLICATION .....	20
PART 4.	INTERCONNECTION AGREEMENT.....	25
PART 5.	CERTIFICATE OF COMPLETION .....	28
PART 6.	APPROVAL TO ENERGIZE GENERATION FACILITY.....	29
PART 7.	PARALLEL RENEWABLE GENERATION APPLICATION FOR SERVICE .....	30

## PART 1. OVERVIEW

### 1. PURPOSE:

The purpose of this document is to establish standards for eligible customers (“Customer”) to interconnect and operate Customer-Owned inverter-based renewable Generation Facilities with a rated output of 25 kilowatts Alternating Current (kW<sub>AC</sub>) or less in parallel with the City of Hamilton (“City”) Electric Distribution System.

### 2. DEFINITIONS:

- a. **AC** – Alternating Current
- b. **Applicable Laws and Regulations** – All duly promulgated applicable federal, state and local laws, regulations, rules, ordinances, codes, decrees, judgments, directives, or judicial or administrative orders, permits and other duly authorized actions of any Governmental Authority, including the Ordinances of the City of Hamilton and City Electric Department General Rules and Regulations.
- c. **City** – The City of Hamilton, Ohio.
- d. **Commercial Operation Date** – The date on which the Generation Facility is operating and is in compliance with the requirements of these Interconnection Standards for Installation and Parallel Operation of Customer-owned Renewable Electric Generation Facilities 25 kW<sub>AC</sub> or Less as determined by Utility.
- e. **Credit Meter** – A single bidirectional meter capable of recording the flow of electricity in each direction at the Customer-owned Generation Facility.
- f. **Customer** – a Residential or Commercial electric customer interconnected to the Electric Distribution System for the purpose of receiving retail electric service that also owns and operates an approved Generation Facility.
- g. **DC** – Direct Current
- h. **Electric Distribution System** – The City facilities and equipment used to provide electric service to customers, including the Customer.
- i. **Generation Facility** – For purposes of these Interconnection Standards, the Customer device for conversion of renewable to electricity, as identified in the Interconnection Application, that:
  1. Is an inverter-based energy facility with a rated capacity and output of 25 kW<sub>AC</sub> or less when including any storage capabilities;
  2. Is owned by the Customer;
  3. Is located on the Customer’s premises;
  4. Serves only the Customer’s premises (serves no other customers)
  5. Is interconnected with and operates in parallel phase and synchronization with the Electric Distribution System and is in compliance with these Interconnection Standards;

6. Is intended primarily to offset part of the Customer's own electrical energy requirements;
7. Contains a Utility-approved mechanism(s) that automatically disconnects the Generation Facility and interrupts the flow of electricity to the Electric Distribution System in the event that electric service to the Customer is interrupted.
8. Meets all of the following generating capacity limitations:
  - a. Generation Facility annual energy production shall not exceed Customer's annual energy requirements.
  - b. Customer's Generation Facility in kW<sub>AC</sub> shall not exceed Customer's average annual demand when historical demand (kW) meter readings are unavailable for the previous 12-month period starting January 1 and ending December 31, or 25 kW, whichever is less. Customer's estimated average annual demand shall be calculated by using said customer's historical annual energy usage in kWh divided by 8,760 hours and then divided by 30%.
9. In addition to the requirements in Part 1. (2)(8), if the Customer Generation Facility exceeds the existing operating capabilities of the distribution lines and equipment, one of the following methods shall be required to minimize any exportation of energy from the customer owned generator.
  - a. A reverse power relay should be installed to monitor power flow at the Point of Interconnection (PCC). The relay should be set to disconnect the Customer-owned Generation Facility from the Electric Distribution System when reverse power flow or export of power to the Utility at the PCC exceeds 0.1% of the service transformer's rating, with a maximum 2.0 second delay.
  - b. Install dynamically controlled inverters (DCI) that monitor power flow at the PCC and will initiate a reduction of power output from the Generation Facility to maintain a minimum import level.
- j. **Governmental Authority** – Any federal, state, local or other governmental regulatory or administrative agency, court, commission, department, board, or other governmental subdivision, legislature, rulemaking board, tribunal, or other governmental authority having jurisdiction over the Parties, their respective facilities, or the respective services they provide, and exercising or entitled to exercise any administrative, executive, police, or taxing authority or power; provided, however, that such term does not include the Customer or any Affiliate thereof.
- k. **Harmonic Distortion** – Distortion of the normal AC sine wave typically caused by non-linear loads or inverters.
- l. **Point of Interconnection** – Point of service as defined in the Utility's Rules and Regulations.

- m. **Interconnection Application** – The Customer request to interconnect a new Generation Facility, or to increase the capacity of, or make a material modification to the operating characteristics of an existing Generation Facility that is interconnected with the Electric Distribution System.
- n. **Interconnection Standards** – Interconnection Standards shall mean all provisions, forms and related documents described in the collective parts of these Interconnection Standards for Installation and Parallel Operation of Customer-Owned Renewable Electric Generation Facilities 25 kW<sub>AC</sub> or Less, or successor document.
- o. **Load Meter** – The electric Utility meter that measures the flow of electricity required to serve Customer’s premises.
- p. **Party** – Individually the Utility and the Customer; collectively the “Parties.”
- q. **Prudent Utility Practice** – Any of the practices, methods and acts engaged in or approved by a significant portion of the electric utility industry during the relevant time period, or any of the practices, methods and acts which, in the exercise of reasonable judgment in light of the facts known at the time the decision was made, could have been expected to accomplish the desired result at a reasonable cost consistent with good business practices, reliability, safety and expedition. Prudent Utility Practice is not intended to be limited to the optimum practice, method, or act to the exclusion of all others, but rather to be acceptable practices, methods, or acts generally accepted by the electric utility industry in the region.
- r. **Reasonable Efforts** – With respect to an action required to be attempted or taken by a Party under the Interconnection Agreement, efforts that are timely and consistent with Prudent Utility Practice and are otherwise substantially equivalent to those a Party would use to protect its own interests.
- s. **System Upgrades** – Additions, modifications, improvements, and upgrades to the Electric Distribution System or Customer service connection at or beyond the point of interconnection to facilitate interconnection of the Customer Generation Facility.
- t. **Utility** – The City of Hamilton municipal electric system.
- u. **Voltage Flicker** – A variation of voltage sufficient in duration to allow visual observation of a change in electric light source intensity.

**3. ELIGIBILITY:**

- a. Must be a Residential or Commercial electric customer with a Customer-owned inverter-based renewable energy Generation Facility as defined herein. Point of Interconnection shall be ahead of the Utility’s Load Meter and operated in parallel with the electric Utility and single-phase or three-phase service at 60 Hertz at a nominal voltage of 120/240 volts 208 volts or 480 volts. A single bidirectional electric meter (Credit Meter) or meters capable of recording the flow of electricity in each direction or multiple meters shall be installed to measure the flow of electricity at the Generation Facility. Specific metering shall be at the Utility’s discretion.

- b. Customer's utility account must be in good standing and in compliance with City electric rate schedules and Electric Department General Rules and Regulations.
- c. A Generation Facility that does not meet all of the requirements of Section 2h. above, including capacity limitations, is not eligible to interconnect with the Electric Distribution System under these Interconnection Standards. Such facilities are subject to separate negotiation with the City.

**4. INTERCONNECTION REQUEST:**

The Customer shall request interconnection of a Generation Facility by completing and submitting to the Utility the attached document entitled "Interconnection Application". The Utility may require additional information or clarification to evaluate the Customer Interconnection Request. Interconnection Applications will be reviewed by the Utility in the order in which they are received. If an Interconnection Application is viewed as incomplete, the Utility will provide notice to the Customer that the Application is not complete, provide a description of the information needed to complete the Application and include a statement that processing of the Application cannot begin until the Application is complete.

**5. ELECTRIC DISTRIBUTION SYSTEM IMPACT ANALYSIS:**

After receiving a properly completed Interconnection Application, the Utility will analyze the potential impact of the Generation Facility on the Electric Distribution System and on other Utility customers. Such analyses will be based on Prudent Utility Practice to determine thermal effects, voltage ranges, power quality, system stability, etc., and will include the following:

- a. The Customer Generation Facility's proposed Point of Interconnection is on a radial distribution circuit and not a transmission line.
- b. The proposed Generation Facility complies with IEEE 1547 and UL 1741 standards.
- c. The proposed Generation Facility's capacity in aggregation with other generation on the circuit shall not exceed 15 percent (15%) of the total circuit peak demand (kW) as most recently measured at the substation during the previous 12-month period; nor shall it exceed 15 percent (15%) of a distribution circuit line section annual peak demand (kW).
- d. The proposed Generation Facility, in aggregation with other generation on the distribution circuit, shall not contribute more than 10 percent (10%) to the distribution circuit's maximum fault current at the point on the primary voltage distribution line nearest the proposed interconnection point.
- e. The proposed Generation Facility, in aggregation with other Customer-owned Generation Facilities connected to the distribution circuit, may not cause any distribution protective devices and equipment (including substation breakers, fuse cutouts, and line reclosers, or other customer equipment on the electric distribution system to be exposed to fault currents exceeding 85 percent (85%) of the short circuit interrupting capability.

- f. No additional Generation Facilities shall be interconnected on a circuit that already exceeds 85 percent (85%) of its short circuit interrupting capability.
- g. When a proposed Generation Facility is single-phase and is to be interconnected on a center tap neutral on a 240-volt service, its addition shall not create an imbalance between the two sides of the 240-volt service of more than 20 percent of the nameplate rating of the service transformer.
- h. The proposed Generation Facility installation must be certified to pass an applicable non-islanding test, or use reverse power relays or other means to meet IEEE 1547 unintentional islanding requirements.
- i. On a three-phase, three-wire primary electric distribution line, a three- or single-phase generator shall be connected phase-to-phase.
- j. When the Applicant's facility is to be connected to three-phase, four-wire primary distribution lines, a three- or single-phase generator shall be connected line-to-neutral and shall be effectively grounded.
- k. A review of the type of electrical service provided to the Customer, including line configuration, and the transformer connection, shall be conducted to limit the potential for creating over-voltage on the Electric Distribution System due to a loss of ground during the operation time of any anti-islanding function.
- l. When the proposed Generation Facility is to be interconnected on a single-phase shared secondary line, the aggregate generation capacity on the shared secondary line, including the proposed Generation Facility, shall not exceed ten kilowatts (10 kW).

### **Feasibility Analysis**

If the proposed Generation Facility fails to meet one or more of the above requirements, the Customer may request the Utility to complete an analysis to determine the feasibility of interconnecting the proposed Generation Facility to the Electric Distribution System. The Feasibility Analysis shall include:

- 1. Initial identification of any circuit breaker short-circuit capability limits exceeded as a result of the interconnection.
- 2. Initial identification of any thermal overload or voltage limit violations resulting from the interconnection.
- 3. Initial review of grounding requirements and system protection.
- 4. A description and nonbinding estimated cost of facilities required, in the Utility's sole determination, to interconnect the Generation Facility to the Electric Distribution System in a safe and reliable manner.

The actual cost of the Feasibility Analysis shall be paid by the Customer. The Utility will provide an estimated cost of the Feasibility Analysis to Customer. Customer shall advance 50% of such estimate to Utility if Customer requests the Utility to prepare the Feasibility Analysis. When Feasibility Analysis cost exceeds 50% of the estimated cost, Utility shall bill Customer as such fees are incurred.



### **System Impact Study**

If the Feasibility Analysis concludes that interconnection of the proposed Generation Facility would create an adverse system impact, a System Impact Study is required.

A System Impact Study shall evaluate the impact of the proposed Generation Facility interconnection on the safety and reliability of the Electric Distribution system. The study shall:

1. Identify and detail the system impacts that result if the proposed Generation Facility is interconnected without project or system modifications.
2. Consider the adverse system impacts or potential impacts identified in the Feasibility Analysis.
3. Consider all Generating Facilities that, on the date the System Impact Study is commenced, are directly interconnected with the Electric Distribution System.
4. Consider pending Interconnection Applications of Generation Facilities requesting interconnection to the Electric Distribution System.

The System Impact Study shall consider the following criteria:

1. A load flow study.
2. A short circuit analysis.
3. A stability analysis.
4. Voltage drop and flicker studies.
5. Protection and set point coordination studies.
6. Grounding reviews.

The Utility shall state the underlying assumptions of the Study and show the results of the analyses to the Customer, including the following:

1. Any potential impediments to providing the requested interconnection service.
2. Any required Electric Distribution System upgrades and the estimated cost and time to engineer and construct said System Upgrades.

The actual cost of the System Impact Study shall be paid by the Customer. The Utility will provide an estimated cost of the System Impact Study to Customer and Customer shall advance 50% of such estimate to Utility if Customer requests the Utility to prepare the System Impact Study. When System Impact Study cost exceeds 50% of the estimated cost, Utility shall bill Customer as such fees are incurred.

### **6. SYSTEM UPGRADES:**

The City shall not be obligated to make upgrades or improvements to its Electric Distribution System to accommodate the Customer's Generation Facility. Where System Upgrades are required prior to interconnection of the Generation Facility as identified in the

Feasibility Study and/or System Impact Study, the Utility will provide the Customer with an estimated schedule and the Customer's cost for said System Upgrades.

**7. INTERCONNECTION AGREEMENT:**

After the Customer and the Utility have identified and mutually agreed on the project scope including the Generation Facility, System Upgrades and estimated costs (if any), the Customer and the Utility shall execute the attached document entitled "Interconnection Agreement." The Interconnection Agreement shall be between the Utility and the Customer and shall not include third parties. Prior to commencement of System Upgrades required to allow interconnection of the Customer-owned Generation Facility, Customer shall deposit with the Utility an amount equal to the estimated cost of said System Upgrades. See Part 4. Interconnection Costs of the Interconnection Agreement for additional information.

**8. CODES AND PERMITS:**

- a. The Customer shall be responsible for procuring all building, operating, environmental or other permits for the Generation Facility and for the necessary ancillary structures to be installed that are required by any Governmental Authority having jurisdiction.
- b. The Generation Facility and interconnecting equipment shall meet the requirements listed in "Part 2. Technical Requirements" of these Interconnection Standards.
- c. The construction and facilities shall meet all applicable building and electrical codes.

**9. CERTIFICATE OF COMPLETION:**

Upon completion of the Generation Facility and prior to the Commercial Operation Date of said Generation Facility, the Customer shall complete and submit a signed copy of the attached document entitled "Certificate of Completion." See Part 5. Certificate of Completion.

**10. NORMAL OPERATION:**

The Customer may begin Commercial Operation of the Generation Facility upon receipt of written approval from the Utility.

## **PART 2. TECHNICAL REQUIREMENTS**

### **1. CHARACTER OF SERVICE:**

The electric service shall be 60 cycles per second (60 Hertz) alternating current (AC) at supply voltages and number of phases under the Residential or Commercial electric rate schedule that would apply if the Customer did not have an interconnected Generation Facility.

### **2. CODE REQUIREMENTS:**

The Generation Facility shall meet all requirements established by the National Electrical Code (NEC), National Electrical Safety Code (NESC), Institute of Electrical and Electronics Engineers (IEEE), Underwriters Laboratories (UL), and the Occupational Safety and Health Administration. Specific applicable codes are shown in Section 9 of this Part 2 below as “Standards for Interconnection, Safety and Operating Reliability.” In addition, manufacturer’s ownership, operating and maintenance manuals or documents shall be provided to the Electric Utility with the Customer Interconnection Application. The Electric Utility shall review said manuals or documents as part of the Interconnection Application review process.

### **3. GENERATION FACILITY CONTROL:**

The control system of the Generation Facility shall comply with IEEE and UL specifications and standards for parallel operation with the Electric Distribution System and in particular as follows:

- a. Power output control system shall automatically disconnect from the Electric Distribution System upon loss of System voltage and shall not reconnect until System voltage has been restored by the Utility for at least 10 minutes
- b. Power output control system shall automatically disconnect from the Electric Distribution System if System voltage fluctuates beyond plus or minus ten percent (10%).
- c. Power output control system shall automatically disconnect from the Electric Distribution System if the generator fails to operate within the operating frequency range of 59.3 – 60.5 Hz.
- d. Inverter output Harmonic Distortion shall meet IEEE and UL standards.
- e. The Generation Facility shall meet applicable IEEE and UL standards concerning impacts to the Electric Distribution System with regard to Harmonic Distortion, Voltage Flicker, power factor, direct current injection and electromagnetic interference.

### **4. LIMITS SPECIFIC TO SINGLE-PHASE GENERATING FACILITIES:**

When connected to a single phase transformer, the Generation Facility must be installed such that the aggregated gross output is balanced between the two phases of the single phase voltage and the maximum aggregated gross ratings for all the Generating Facilities shall not exceed the transformer rating.

**4.1 LIMITS SPECIFIC TO THREE-PHASE GENERATING FACILITIES:**

The applicant must balance the load demand and generation as nearly as practical between the two sides of a three-wire single-phase service and between all phases of a three-phase service.

The difference in amperes between any two phases at the customer's peak load should not be greater than 10 percent or 50 amperes (at the service delivery voltage), whichever is greater; except that the difference between the load on the lighting phase of a four-wire delta service and the load on the power phase may be more than these limits. It will be the responsibility of the customer to keep the load demand balanced within these limits.

**5. SYSTEM PROTECTION:**

The owner of the Customer-owned Generation Facility is responsible for providing adequate protection to Utility facilities for conditions arising from the operation of generation under all Electric Utility Distribution System operating conditions. The customer is also responsible for providing adequate protection to their Generation Facility under any Electric Distribution System operating condition whether or not their Customer-owned Generation Facility is in operation. Conditions may include but are not limited to:

- a. Loss of a single phase of supply,
- b. Distribution system faults,
- c. Equipment failures,
- d. Abnormal voltage or frequency,
- e. Lightning and switching surges,
- f. Excessive harmonic voltages,
- g. Excessive negative sequence voltages,
- h. Separation from supply,
- i. Synchronizing generation,
- j. Re-synchronizing the Owner's generation after electric restoration of the supply.

**6. FAULT CURRENT DISCONNECTION:**

The Generation Facility shall be equipped with protective equipment designed to automatically disconnect from the Electric Distribution System during fault current conditions and remain disconnected until System voltage and frequency have stabilized for 10 minutes.

**7. RECLOSING COORDINATION:**

The Generation Facility shall be coordinated with Electric Distribution System reclosing devices by disconnecting from the System during de-energized System operation. The Generation Facility shall remain disconnected until System voltage and frequency have stabilized for 10 minutes.

**8. EXTERIOR GENERATION FACILITY AC DISCONNECT SWITCH:**

The Customer shall install an exterior alternating current (AC) fused disconnect switch within six (6) feet of the Utility electric meter(s) that is visible and readily accessible to Utility representatives at all times. This switch shall be clearly labeled as “Generator AC Disconnect Switch”. The switch shall be capable of being locked in an open position and shall prevent the Generation Facility from supplying power to the Electric Distribution System while in the open position.

**9. STANDARDS FOR INTERCONNECTION, SAFETY AND OPERATING RELIABILITY:**

The interconnection of a Generation Facility and associated equipment to the Electric Distribution System shall meet the applicable provisions of the following publications or successor standards:

- a. ANSI/IEEE1547-2003 Standard for Interconnecting Distributed Resources with Electric Power Systems (including use of IEEE 1547.1 testing protocols to establish conformity). The following standards shall be used as guidance in applying IEEE 1547:
  1. IEEE Standard 519-1992, IEEE Recommended Practices and Requirements for Harmonic Control in Electrical Power Systems
  2. IEC/TR3 61000-3-7 Assessment of emission limits for fluctuating loads in MV and HV power systems
- b. UL 1741 Standard for Inverters, Converters and Controllers for Use in Independent Power Systems
- c. ANSI/NFPA 70 (2008), National Electrical Code
- d. OSHA (29 CFR § 1910.269)
- e. IEEE Standard 929-2000, *IEEE Recommended Practice for Utility Interface of Photovoltaic (PV) Systems*
- f. IEEE Standard C37.90.1-1989 (R1994), *IEEE Standard Surge Withstand Capability (SWC) Tests for Protective Relays and Relay Systems*
- g. IEEE Standard C37.90.2 (1995), *IEEE Standard Withstand Capability of Relay Systems to Radiated Electromagnetic Interference from Transceivers*
- h. IEEE Standard C62.41.2-2002, *IEEE Recommended Practice on Characterization of Surges in Low Voltage (1000V and Less) AC Power Circuits*
- i. IEEE Standard C62.45-1992 (R2002), *IEEE Recommended Practice on Surge Testing for Equipment Connected to Low-Voltage (1000V and Less) AC Power Circuits*

- j. IEEE Standard 100-2000, IEEE Standard Dictionary of Electrical and Electronic Terms
- k. ANSI C84.1-1995 *Electric Power Systems and Equipment – Voltage Ratings (60 Hertz)*
- l. NEMA MG 1-1998, Motors and Generators, Revision 3
- m. IEEE Standard 2030.2, Guide for the Interoperability of Energy Storage Systems Integrated with the Electric Power Infrastructure (Including use of IEEE 2030.3 testing protocols to establish conformity).

**10. ACCESS AND INSPECTION BY UTILITY:**

Customer shall provide the Utility reasonable opportunity to inspect the Generation Facility prior to its interconnection and Commercial Operation Date and to witness initial testing and commissioning of the Generation Facility. The Utility may witness any commissioning tests required by IEEE 1547/UL 1741.

Following initial testing and inspection of the Generation Facility and upon reasonable advance notice to Customer, the Utility shall have access at reasonable times to the Generation Facility to perform on-site inspections to verify that the installation, maintenance and operation of the Generation Facility complies with the requirements of these Interconnection Standards. The Utility cost of such inspection(s) shall be at the Utility's expense; however, the Utility shall not be responsible for any other cost Customer may incur as a result of such inspection(s). Upon written request, Customer shall inform the Utility of the next scheduled maintenance and allow the Utility to witness the maintenance program and any associated testing.

The Utility shall at all times have immediate access to the exterior Generation Facility AC disconnect switch to isolate the Generation Facility from the Electric Distribution System.

**11. GENERATION FACILITY OPERATION:**

- a. Customer shall install, operate, and maintain, at Customer's sole cost and expense, the Generation Facility in accordance with the manufacturer's suggested practices for safe, efficient and reliable operation of the Generation Facility in parallel with the Electric Distribution System. Customer shall bear full responsibility for the installation, maintenance and safe operation of the Generation Facility. Upon request from the Utility, Customer shall supply copies of periodic test reports or inspection logs.
- b. Customer shall be responsible for protecting, at Customer's sole cost and expense, the Generation Facility from any condition or disturbance on the Electric Distribution System, including, but not limited to, voltage sags or swells, system faults, outages, loss of a single phase of supply, equipment failures, and lightning or switching surges.
- c. Customer agrees that, without prior written permission from the Utility, no changes shall be made to the configuration of the Generation Facility as approved by the Utility, and no relay or other control or protection settings shall be set, reset, adjusted or

tampered with, except to the extent necessary to verify that the Generation Facility complies with Utility-approved settings.

- d. Customer shall operate the Generation Facility in such a manner as not to cause undue voltage fluctuations, power quality issues, intermittent load characteristics or to otherwise interfere with the operation of the Electric Distribution System. At all times when the Generation Facility is operated in parallel with the Electric Distribution System, Customer shall operate said Generation Facility in such a manner that no disturbance will be produced thereby to the service rendered by the Utility to any of its other customers or to any electric system interconnected with the Electric Distribution System. Customer understands and agrees that the interconnection and operation of the Generation Facility pursuant to these Interconnection Standards is secondary to, and shall not reduce the safety, quality, or reliability of electric service provided by the Utility.
- e. Customer's control equipment for the Generation Facility shall immediately, completely, and automatically disconnect and isolate the Generation Facility from the Electric Distribution System in the event of a fault on the Electric Distribution System, a fault on Customer's electric system, or loss of a source or sources on the Electric Distribution System. The automatic disconnecting device included in such control equipment shall not be capable of reclosing until after service is restored on the Electric Distribution System. Additionally, if the fault is on Customer's electric system, such automatic disconnecting device shall not be reclosed until after the fault is isolated from the Customer's electric system.

## **12. RIGHT TO DISCONNECT GENERATION FACILITY:**

The Electric Utility shall have the right and authority to disconnect and isolate the Generation Facility without notice at the Utility's sole discretion if the Utility believes that any of the following has occurred or is occurring:

- a. Electric service to Customer's premises is discontinued for any reason;
- b. Adverse electrical effects (such as power quality problems) on the Electric Distribution System and/or the electrical equipment of other Utility customers attributed to the Generation Facility as determined by the Utility.
- c. Electric Distribution System emergencies or maintenance requirements
- d. Hazardous conditions existing on the Electric Distribution System as a result of the operation of the Generation Facility or protective equipment
- e. Failure of the Customer to obtain and maintain required insurance and to provide the Utility with proof of insurance within ten (10) days of request.
- f. Utility identification of uninspected or unapproved equipment or modifications to the Generation Facility after initial approval.

- g. Recurring abnormal operation, substandard operation or inadequate maintenance of the Generation Facility.
- h. Noncompliance with the obligations under the Interconnection Agreement. In non-emergency situations, the Utility shall give Customer notice of noncompliance including a description of the specific noncompliance condition and allow Customer a reasonable time to cure the noncompliance prior to disconnecting and isolating the Generation Facility.
- i. Failure to remit payment to the Utility for any amounts owed, including but not limited to, amounts invoiced pursuant to Section 15 of Part 2.
- j. In the event that the Utility disconnects the Generation Facility for routine maintenance, the Utility shall make reasonable efforts to reconnect the Generation Facility as soon as practicable.
- k. The Customer retains the option to temporarily disconnect the Generation Facility from the Electric Distribution System at any time. Such temporary disconnection shall not constitute termination of the Interconnection Agreement unless the Customer exercises its termination rights under Section 16 of Part 2..

**13. RATES AND OTHER CHARGES:**

- a. Customer must participate in the applicable Utility Parallel Renewable Generation Rate Schedule as a condition of interconnecting a Customer-owned Generation Facility.
- b. Customer must complete and submit to the Utility the Renewable Energy Parallel Generation-Application For Service in Part 7. The Utility shall not approve a Customer-owned Generation Facility Interconnection Application that does not include a completed Renewable Energy Parallel Generation Application For Service.
- c. Terms and conditions of service are contained in the applicable Parallel Renewable Generation rate schedule, Interconnection Standards for Installation and Parallel Operation of Customer-owned Renewable Electric Generation Facilities 25 kW<sub>AC</sub> or Less and Ordinance No. \_\_\_\_\_.
- d. Customer must participate in the Utility's applicable Parallel Renewable Generation rate schedule if the Customer wishes to receive credit for any energy generated by the Customer-owned Generation Facility and delivered to the Utility.

**14. INSURANCE:**

Customer shall at its own expense obtain and continuously maintain insurance covering liability for bodily injury and property damage, without any exclusion for liabilities related to the interconnection undertaken pursuant to the Interconnection Agreement. Customer shall also insure all property and equipment relating to the ownership and operation of the Customer Generation Facility. The amount of such insurance shall be sufficient to insure against all reasonably foreseeable liabilities and risks related to the Generation Facility, the ownership and operation of such Generation Facility, and the interconnection itself. Such



insurance must be obtained from an insurance provider authorized to do business in the State of Ohio. Customer shall provide proof of insurance to the Utility not later than ten (10) days prior to the commercial operation date of the Generation Facility. Utility shall not interconnect the Generation Facility absent submission by the Customer of proof of insurance in accordance with these Interconnection Standards. Thereafter Customer shall provide proof of insurance to the Utility within ten (10) days of such request by the Utility. Utility receipt of proof of insurance does not imply an endorsement of the terms and conditions of said coverage. Customer shall promptly notify the Utility whenever an accident or incident occurs resulting in injuries or damages that are included within the scope of coverage of such insurance, whether or not Customer intends to submit a claim under such policy. Notwithstanding anything herein to the contrary, Customer, on Customer's behalf and on behalf of its insurer(s), hereby waives any rights of recovery and/or subrogation it may otherwise have had against the City of Hamilton for loss or damage to person or property to the extent covered under any policy of insurance required of Customer hereunder.

#### **15. LIMITATION OF LIABILITY AND INDEMNIFICATION:**

a. Limitation of Liability

Subject to the provisions of Paragraph 14 as regards insured losses, each Party's liability to the other Party for any loss, cost, claim, injury, liability, or expense, including reasonable attorney's fees and court fees, relating to or arising from any act or omission in its performance of the Interconnection Agreement, shall be limited to the amount of direct damage actually incurred. In no event shall the Utility or the City of Hamilton be liable for any indirect, special, consequential, or punitive damages.

b. Indemnity

Customer assumes all liability for, and shall indemnify, defend and hold the Utility and the City of Hamilton harmless from, any and all claims, losses, costs, and expenses of any kind or character, direct or indirect, including claims and actions relating to injury to or death of any person or damage to property, demand, suits, recoveries, costs and expenses, court costs, attorney fees, labor costs, and all other obligations by or to third parties arising out of or resulting from the design, construction, operation or maintenance of the Generation Facility, or the Customer's actions or omissions in breach of its obligations under the Interconnection Agreement. Such indemnity shall include, but is not limited to, financial responsibility for: (a) the electric Utility's monetary losses; (b) reasonable costs and expenses of defending an action or claim made by a third party; (c) damages related to the death or injury of a third party; (d) damages to the property of the electric Utility; (e) damages to the property of a third party; (f) damages for the disruption of the business of a third party. The limitations of liability provided in this paragraph do not apply in cases of gross negligence or intentional wrongdoing. If the Utility or the City of Hamilton incurs any costs as to which the indemnity provided in this section 15.b. applies, the Utility or City of

Hamilton shall invoice the Customer for such costs in writing. Customer shall remit payment to the Utility or the City of Hamilton, as appropriate, within 45 calendar days of the date of such invoice.

**16. EFFECTIVE TERM AND TERMINATION RIGHTS:**

The Interconnection Agreement shall become effective when executed by both Parties and shall continue in effect until terminated in accordance with the provisions of this Section. The Interconnection Agreement may be terminated for the following reasons:

- a. Electric service to Customer's premises is discontinued for any reason. If electric service is disconnected for any reason or a change occurs in the account holder, a new Interconnection Application must be submitted to the Utility for consideration;
- b. Customer may terminate the Interconnection Agreement at any time by giving the Utility at least sixty (60) days' prior written notice stating Customer's intent to terminate the Agreement at the expiration of such notice period;
- c. the Utility may terminate the Agreement at any time following Customer's failure to generate energy from the Generation Facility in parallel with the Electric Distribution System by the later of two (2) years from the date of execution of the Interconnection Agreement or during any twelve- (12-) month period following completion of the interconnection provided for by the Agreement;
- d. the Utility may terminate the agreement at any time by giving Customer at least sixty (60) days' prior written notice in the event the Customer generates and delivers to the Utility more energy than Customer consumes within a calendar year for two consecutive years or more.
- e. either Party may terminate the Interconnection Agreement at any time by giving the other Party at least sixty (60) days' prior written notice that the other Party is in default of any of the material terms and conditions of the Interconnection Agreement or these Interconnection Standards for Installation and Parallel Operation of Customer-owned Renewable Electric Generation Facilities 25 kW<sub>AC</sub> OR LESS, so long as the notice specifies the basis for termination and there is reasonable opportunity for the Party in default to cure the default; or
- f. the Utility may terminate the Interconnection Agreement at any time by giving Customer at least sixty (60) days' prior written notice in the event that there is a change in an applicable rule or statute affecting the Agreement.

Upon termination of the Interconnection Agreement, Customer's Generation Facility shall be permanently disconnected from the Electric Distribution System.

Termination of the Interconnection Agreement shall not relieve either party of its liabilities and obligations, owed or continuing at the time of said termination.

**17. TERMINATION OF ANY APPLICABLE PRIOR AGREEMENT:**

From and after the date when service commences under the Interconnection Agreement, the Agreement shall supersede any oral and/or written agreement or understanding between the Utility and Customer concerning the interconnection service covered by the Agreement. Any such prior agreement or understanding shall be deemed to be terminated as of the date interconnection service commences under the Interconnection Agreement.

**18. FORCE MAJEURE:**

For purposes of the Interconnection Agreement, the term “Force Majeure” means any cause or event not reasonably within the control of the Party claiming Force Majeure, including, but not limited to, the following: acts of God, strikes, lockouts, or other industrial disturbances; acts of public enemies; orders or permits or the absence of the necessary orders or permits of any kind which have been properly applied for from the government of the United States, the State of Ohio, any political subdivision or municipal subdivision or any of their departments, agencies or officials, or any civil or military authority; unavailability of a fuel or resource used in connection with the generation of electricity; extraordinary delay in transportation; unforeseen soil conditions; equipment, material, supplies, labor or machinery shortages; epidemics; landslides; lightning; earthquakes; fires; hurricanes; tornadoes; storms; floods; washouts; drought; arrest; war; civil disturbances; explosions; breakage or accident to machinery, transmission lines, pipes or canals; partial or entire failure of utilities; breach of contract by any supplier, contractor, subcontractor, laborer or materialman; sabotage; injunction; blight; famine; blockade; or quarantine. A Force Majeure event does not include an act of negligence or intentional wrongdoing.

If either Party is rendered wholly or partly unable to perform its obligations under the Interconnection Agreement because of Force Majeure, both Parties shall be excused from whatever obligations under the Agreement are affected by the Force Majeure (other than the obligation to pay money) and shall not be liable or responsible for any delay in the performance of, or the inability to perform, any such obligations for so long as the Force Majeure continues. The Party suffering an occurrence of Force Majeure shall, as soon as is reasonably possible after such occurrence, give the other Party written notice describing the particulars of the occurrence and shall use reasonable efforts to remedy its inability to perform; provided, however, that the settlement of any strike, walkout, lockout or other labor dispute shall be entirely within the discretion of the Party involved in such labor dispute.

**PART 3. INTERCONNECTION APPLICATION**

Application No. \_\_\_\_\_

**City of Hamilton**

**Customer-Owned Renewable Electric Generation Facility 25 kW<sub>AC</sub> or Less**

This Application for Interconnection of a Customer-Owned Renewable Electric Generation Facility 25 kW<sub>AC</sub> or less is considered complete when it provides all applicable and correct information required below. The City may require additional information or clarification to evaluate the Interconnection Application.

Processing Fee

A non-refundable processing fee of \$250 must accompany this Application.

Customer

Name: \_\_\_\_\_ Utility Account Number: \_\_\_\_\_

Address: \_\_\_\_\_ Utility Location Number: \_\_\_\_\_

City: \_\_\_\_\_ State: \_\_\_\_\_ Zip: \_\_\_\_\_

Telephone (Day): \_\_\_\_\_ (Evening): \_\_\_\_\_

Fax: \_\_\_\_\_ E-Mail Address: \_\_\_\_\_

Is the Generation Facility owned by the Customer listed above?     Yes     No

Contact (if different from Customer)

Name: \_\_\_\_\_

Address: \_\_\_\_\_

City: \_\_\_\_\_ State: \_\_\_\_\_ Zip: \_\_\_\_\_

Telephone (Day): \_\_\_\_\_ (Evening): \_\_\_\_\_

Fax: \_\_\_\_\_ E-Mail Address: \_\_\_\_\_

Generation Facility Information

Location (if different from above): \_\_\_\_\_

Inverter Manufacturer: \_\_\_\_\_

Model \_\_\_\_\_

Number of Phases: \_\_\_\_\_

Nameplate Rating:        (kW) \_\_\_\_\_ (kVA) \_\_\_\_\_

System Design Capacity: (kW<sub>AC</sub>) \_\_\_\_\_ (kVA<sub>AC</sub>) \_\_\_\_\_

Energy Source:  Solar     Wind     Battery/Storage     Other \_\_\_\_\_

Is the Generation Facility equipment IEEE 1547/UL 1741 Certified?     Yes     No

[Note: Requires a Yes for an application to be considered complete.]

If Yes, attach manufacturer's documentation and technical specification sheet showing IEEE 1547/UL 1741 certification

Have all necessary government permits and approvals been obtained for the project prior to this application?

Yes  No [Note: Requires a Yes for an application to be considered complete.]

Utility Accessible Exterior Generation Facility AC Disconnect Switch Provided (Required)  Yes  No

Location of Utility Accessible Exterior Generation Facility AC Disconnect Switch \_\_\_\_\_  
\_\_\_\_\_

(e.g. Two feet west of electric meter)

Estimated Installation Date: \_\_\_\_\_ Estimated Commercial Operation Date: \_\_\_\_\_

List components of the Generation Facility equipment package that are currently certified:

Equipment Type	Certifying Entity
1. _____	_____
2. _____	_____
3. _____	_____
4. _____	_____

**Equipment Installation Contractor: Indicate by owner if applicable**

Name: \_\_\_\_\_

Mailing Address: \_\_\_\_\_

City: \_\_\_\_\_ State: \_\_\_\_\_ Zip Code: \_\_\_\_\_

Contact Person (If other than Above): \_\_\_\_\_

Telephone (Daytime): \_\_\_\_\_ (Evening): \_\_\_\_\_

Facsimile Number: \_\_\_\_\_ E-Mail Address: \_\_\_\_\_

**Electrical Contractor: (If Applicable) Indicate if not applicable**

Name: \_\_\_\_\_

Mailing Address: \_\_\_\_\_

City: \_\_\_\_\_ State: \_\_\_\_\_ Zip Code: \_\_\_\_\_

Contact Person (If other than Above): \_\_\_\_\_

Telephone (Daytime): \_\_\_\_\_ (Evening): \_\_\_\_\_

Facsimile Number: \_\_\_\_\_ E-Mail Address: \_\_\_\_\_

**Consulting Engineer: (If Applicable) Indicate if not applicable**

Name: \_\_\_\_\_

Mailing Address: \_\_\_\_\_

City: \_\_\_\_\_ State: \_\_\_\_\_ Zip Code: \_\_\_\_\_

Contact Person (If other than Above): \_\_\_\_\_

Telephone (Daytime): \_\_\_\_\_ (Evening): \_\_\_\_\_

Facsimile Number: \_\_\_\_\_ E-Mail Address: \_\_\_\_\_

**Provide a one line diagram of the Generation Facility.** The one line diagram is a basic drawing of an electric circuit in which one or more conductors are represented by a single line and each electrical device and major component of the installation, from the Generation Facility to the Point of Interconnection, are noted by symbols. See attached example.

Provide a site layout of the Generation Facility and nearby features. The site layout is a basic drawing showing the location of the Generation Facility, Utility Electric meter, AC and DC disconnect switches, existing electrical panels, disconnects, and utility transformers, conduit/conductor runs and lockout locations.

Copies of manufacturer’s ownership, operating and maintenance manuals for all Generation equipment, inverters, and other proposed Generation Facility equipment must be submitted with this Application.

**Customer Signature**

I hereby certify that, to the best of my knowledge, the information provided in this Interconnection Application is true. I agree to abide by the terms and conditions of the City’s Interconnection Standards for Installation and Parallel Operation of Customer-Owned Renewable Electric Generation Facilities 25 kW<sub>AC</sub> or Less and will return the Certificate of Completion to the Electric Utility when the Generation Facility has been installed and prior to commencing operation of said Generation Facility.

Signature: \_\_\_\_\_ Date: \_\_\_\_\_

E-mail electric permit application, drawings and this application to [building@hamilton-oh.gov](mailto:building@hamilton-oh.gov). All documents need to be submitted at the same time. Two complete hardcopies will also need to be dropped off or mailed to Attn: Ken Rivera, City of Hamilton, 345 High St. Hamilton, OH 45011.

Payment made out to the City of Hamilton for \$250 can be dropped off at the Customer Service Desk, Attn: Darla Bokeno or mailed to Attn: Darla Bokeno, City of Hamilton, 345 High St. Hamilton, OH 45011.

-----**Utility Use**-----

**Contingent Approval to Interconnect the Generation Facility**

Interconnection of the Generation Facility is approved contingent upon Customer compliance with all of the terms and conditions of the Utility’s Interconnection Standards and upon return of the Certificate of Completion prior to commencement of Commercial Operation of said Generation Facility.

Utility Signature: \_\_\_\_\_

Title: \_\_\_\_\_ Date: \_\_\_\_\_

Application Number: \_\_\_\_\_

Utility waives inspection/witness test? Yes No Initial \_\_\_\_\_

# One Line Diagram Example

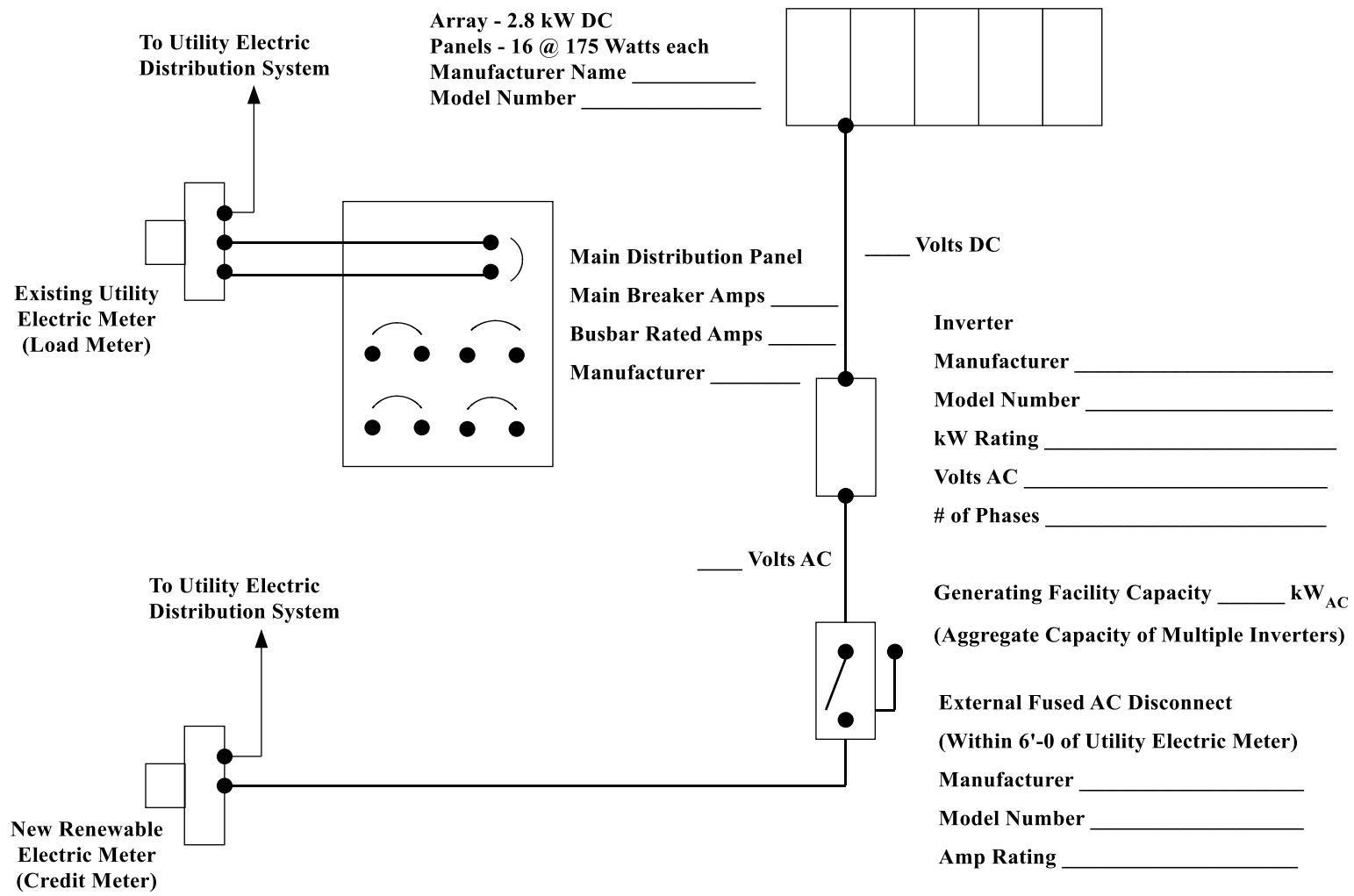

*For Illustrative Purposes Only*

# Sample Site Layout

John Doe  
111 E. Main St.  
City, State Zip Code

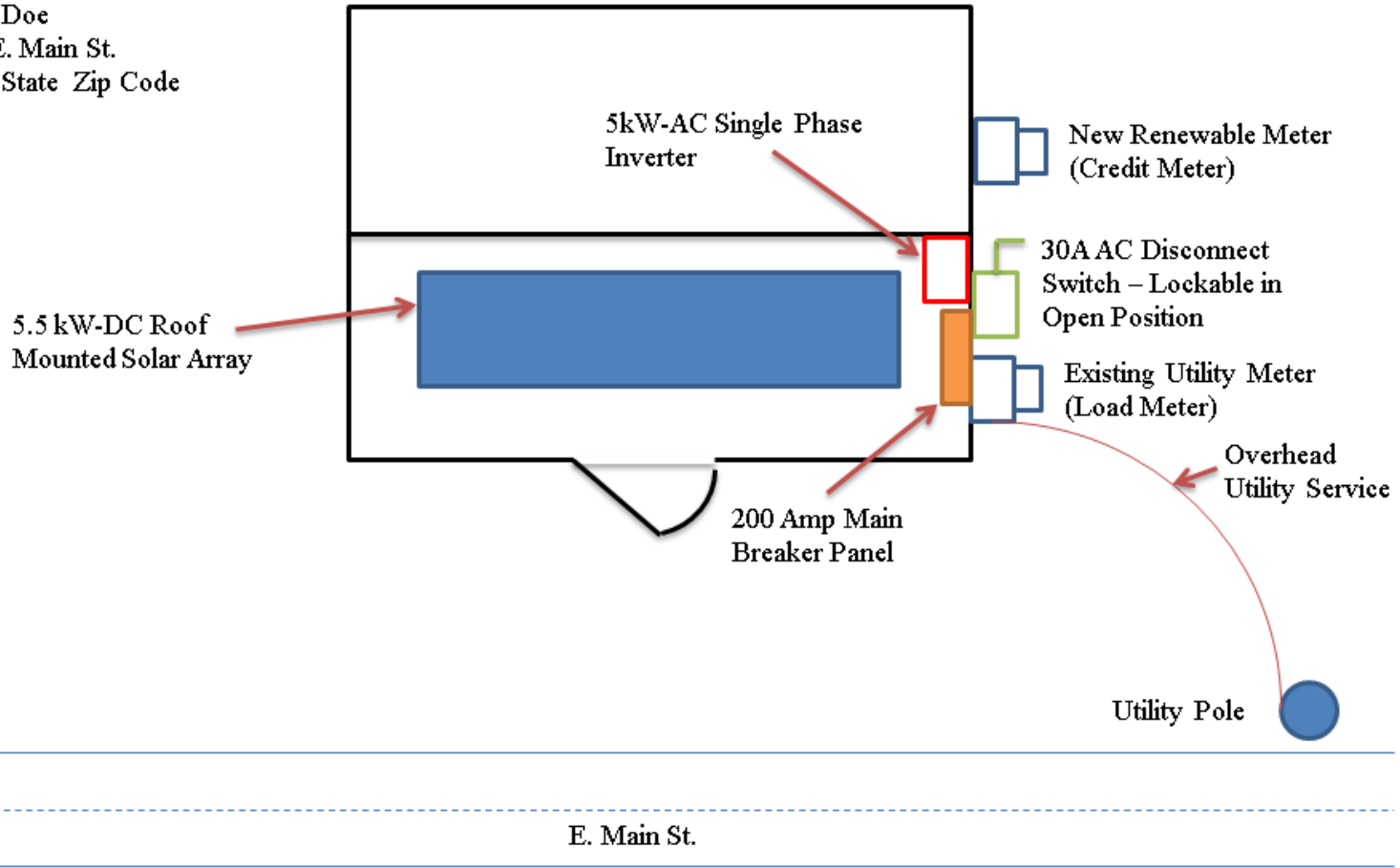



**PART 4. INTERCONNECTION AGREEMENT**

Application No. \_\_\_\_\_

**City of Hamilton  
Customer-Owned Renewable Electric Generation Facility 25 kW<sub>AC</sub> or Less**

This Agreement, (“**Agreement**”) is entered into by and between the City of Hamilton, Ohio (“**Utility**”) and \_\_\_\_\_, (“**Customer**”). The Customer electric account subject to this Agreement is Account Number \_\_\_\_\_. Customer and Utility are referenced in this Agreement collectively as “**Parties**” and individually as “**Party**.”

**Recitals**

WHEREAS, City owns and operates an Electric Distribution System serving the City of Hamilton, Ohio, and surrounding area;

WHEREAS, Customer owns or desires to install, own and operate a Utility-approved renewable, inverter-based electric Generation Facility with a rated output of 25 kW<sub>AC</sub> or less, interconnected with and operating in parallel with the Electric Distribution System;

**Agreement**

NOW, THEREFORE, in consideration of the covenants and promises herein, the Parties mutually agree as follows:

**1. SCOPE OF AGREEMENT:**

This Agreement governs the terms and conditions under which the Generation Facility will interconnect with and operate in parallel with the Electric Distribution System.

**2. DEFINITIONS:**

The definitions used in this Interconnection Agreement are those found in Part 1, Section 2 of the Utility Interconnection Standards for Installation and Parallel Operation of Customer-Owned Renewable Electric Generation Facilities 25 kW<sub>AC</sub> or Less.

**3. PARALLEL OPERATION:**

Customer shall not interconnect or commence parallel operation of the Generation Facility until written Approval to Energize the Generation Facility under Part 6 of these Interconnection Standards has been provided by Utility. Electric Utility shall have the right to have representatives present during initial testing of the Generation Facility and its protective apparatus.

**4. INTERCONNECTION COSTS:**

The Utility has estimated the costs, including overheads, for necessary System Upgrades to its Electric Distribution System and Customer service connection, if any, and has provided a detailed itemization of such costs in the attached description of estimated System Upgrade costs. Prior to commencement of System Upgrades required to allow interconnection of the Customer-owned Generation Facility, Customer shall deposit with the Utility an amount equal to the estimated cost of said System Upgrades. If the actual costs of said System Upgrades are less than the amount deposited by the Customer, the Utility will refund the difference to the Customer within 60 days of completing said System Upgrades. If the actual costs of said System Upgrades exceed the amount deposited by the Customer, the Utility shall bill the Customer for the difference. Customer agrees to pay the invoiced amount within 30 days of the invoice date.

**5. INTERRUPTION OR REDUCTION OF DELIVERIES:**

The Utility may require the Customer to interrupt or reduce energy deliveries when the Utility determines, in its sole discretion, that curtailment, interruption or reduction is necessary because of maintenance, safety, emergency, Force Majeure or compliance with Prudent Utility Practices. No compensation or credit will be provided to the Customer by the Utility for such interruptions or reductions in energy deliveries.

**6. ADVERSE OPERATING EFFECTS:**

The interconnection of the Generation Facility shall not reduce the reliability and quality of the City Electric Distribution System service. This includes, but is not limited to power quality issues such as Harmonic Distortion, Voltage Flicker and frequency deviations. The Utility shall notify the Customer as soon as practicable if, based on Prudent Utility Practice, operation of the Generation Facility causes disruption in or deterioration of service to other Utility customers or if operating the Generation Facility could damage the Electric Distribution System. If, after notice, the Customer fails to timely remedy the adverse operating effect, the Utility may disconnect the Generation Facility with no further notice.

**7. COMPLIANCE WITH INTERCONNECTION STANDARDS REQUIREMENTS:**

Customer has read the Utility Interconnection Standards for Installation and Parallel Operation of Customer-Owned Renewable Electric Generation Facilities 25 kW<sub>AC</sub> or Less, as adopted by the Utility, and agrees to comply with all requirements included therein, including, but not limited to, all insurance and indemnity provisions identified in Sections 14 and 15 of Part 2 therein.

**8. ACCESS TO PREMISES:**

Electric Utility shall have access to the Customer premises or property and to the exterior AC Generation Facility disconnect switch as permitted in its policies, Rules and Regulations and these Interconnection Standards.

**9. GOVERNING LAW:**

This Agreement shall be interpreted and governed under the laws of the State of Ohio, the Ordinances of the City of Hamilton, City Electric Department General Rules and Regulations and applicable City Electric Rates.

**10. DOCUMENTS:**

This Agreement incorporates all other provisions and related documents of these Interconnection Standards for Installation and Parallel Operation of Customer-owned Renewable Electric Generation Facilities 25 kW<sub>AC</sub> or Less as the same may be amended from time to time.

**11. NOTICES:**

All written notices shall be directed as follows:

<b>CUSTOMER:</b>	<b>UTILITY:</b>
Name: _____	Name: _____
Address: _____	Title: _____
City/State/Zip: _____	City/State/Zip: _____

**12. TERM OF AGREEMENT:**

This Agreement shall be in effect when executed by the Customer and Utility and shall remain in effect thereafter month to month unless terminated in accordance with the provisions of Section 16 of “Part 2. Technical Requirements.”

IN WITNESS WHEREOF, the Parties hereto have caused two originals of this Agreement to be executed by their duly authorized representatives.

This Agreement is effective as of the last date set forth below.

<b>CUSTOMER:</b>	<b>For the UTILITY:</b>
_____	_____
Signature	Signature
_____	_____
Print Name	Print Name and Title
_____	_____
Date	Date

**PART 5. CERTIFICATE OF COMPLETION**

Application No. \_\_\_\_\_

**City of Hamilton  
Customer-Owned Renewable Electric Generation Facility**

Is the Generation Facility installed, tested and ready for operation? Yes \_\_\_\_\_ No \_\_\_\_\_

Customer: \_\_\_\_\_ Utility Account Number: \_\_\_\_\_

Address: \_\_\_\_\_

Telephone (Day): \_\_\_\_\_ (Evening): \_\_\_\_\_

Fax: \_\_\_\_\_ E-Mail Address: \_\_\_\_\_

Location of the Generation Facility (if different from above):  
\_\_\_\_\_

Has the Generation Facility been installed in accordance with all applicable building codes, permits and ordinances (if applicable)? \_\_\_\_\_

Electrician/Service Company:

Name: \_\_\_\_\_

Address: \_\_\_\_\_

City/State/Zip: \_\_\_\_\_

Telephone (Day): \_\_\_\_\_ (Evening): \_\_\_\_\_

Fax: \_\_\_\_\_ E-Mail Address: \_\_\_\_\_

License number: \_\_\_\_\_

Date Utility approved Interconnection Application: \_\_\_\_\_

Application number: \_\_\_\_\_

Inspection:

The Generation Facility has been installed and inspected in compliance with all applicable electrical codes.

A copy of the signed electrical inspection form is attached.  Yes  No

(If inspection form is not attached)

\_\_\_\_\_  
Signature of inspector:

\_\_\_\_\_  
Date

\_\_\_\_\_  
Printed name of inspector

**PART 6. APPROVAL TO ENERGIZE GENERATION FACILITY**

Application No. \_\_\_\_\_

**City of Hamilton  
Customer-Owned Renewable Electric Generation Facility**

The City, having entered into an Interconnection Agreement for the Generation Facility described in the Application noted by number above and having received a Certificate of Completion with proper documentation of the electrical inspection hereby authorizes the Generation Facility to be energized:

Utility Signature: \_\_\_\_\_

Title: \_\_\_\_\_ Date: \_\_\_\_\_

**PART 7. PARALLEL RENEWABLE GENERATION APPLICATION FOR SERVICE**

Application No. \_\_\_\_\_

**City of Hamilton**

Customer Name: \_\_\_\_\_

Service Address: \_\_\_\_\_

City: \_\_\_\_\_ State: \_\_\_\_\_ Zip: \_\_\_\_\_

Utility Account Number: \_\_\_\_\_

Contact Person: \_\_\_\_\_

Telephone Number: \_\_\_\_\_

Address: \_\_\_\_\_

City: \_\_\_\_\_ State: \_\_\_\_\_ Zip: \_\_\_\_\_

E-Mail Address: \_\_\_\_\_

This application is for electric service under the applicable City of Hamilton (“Utility”) Parallel Renewable Generation rate schedule for the above customer (“Customer”). The Customer Generation Facility is a renewable Generation Facility as defined in the Utility’s Interconnection Standards for Installation and Parallel Operation of Customer-Owned Renewable Electric Generation Facilities 25 kW<sub>AC</sub> or less.

The Generation Facility qualifies for the Parallel Renewable Generation rate as it meets the definitions and requirements of said Interconnection Standards. Total rated output of the Generation Facility under the applicable Parallel Renewable Generation rate schedule, is \_\_\_\_ kW<sub>AC</sub>. Customer acknowledges that he/she has read the rate schedule and agrees to all terms and conditions contained therein, including without limitation those specified in the Interconnection Standards for Installation and Parallel Operation of Customer-Owned Renewable Electric Generation Facilities 25 kW<sub>AC</sub> or Less. Specifically, the Customer understands and agrees that a Utility approved electric meter or meters capable of registering the flow of electricity in each direction must be in service at the facility. If a Utility-approved meter with this capability is not in service, Customer must submit a written request to the electric Utility to acquire, install, maintain, and read an approved meter at the Customer’s cost. All costs related to installation of said meter or meters shall be borne by the Customer.

Customer acknowledges and agrees that operation of said Generation Facility is intended primarily to offset part of Customer’s electricity requirements, and that the Generation Facility is not sized to exceed the annual electric energy requirements of the Customer’s premises. Customer further acknowledges and agrees that the electric Utility will not provide credit for surplus energy generated

by the Generation Facility under the applicable Parallel Renewable Generation rate schedule that exceeds the Customer's annual energy consumption starting January 1 and ending December 31.

Requested By:

Approved By:

\_\_\_\_\_  
Customer Name

\_\_\_\_\_  
Name

\_\_\_\_\_  
Authorized Signature

\_\_\_\_\_  
Utility Signature

\_\_\_\_\_  
Date

\_\_\_\_\_  
Date

Rejected:

\_\_\_\_\_  
Name

\_\_\_\_\_  
Utility Signature

\_\_\_\_\_  
Reason for Rejection

\_\_\_\_\_  
Date

# HAMILTON PHOTOVOLTAIC PROCESS FLOWCHART

